

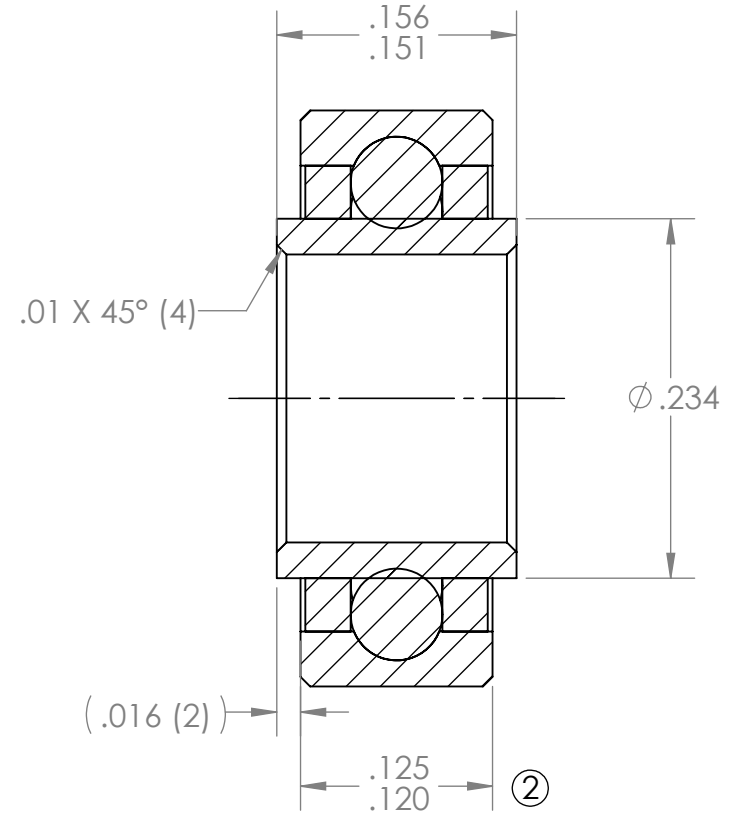

REVISION HISTORY			
REV.	DESCRIPTION	DATE	DRAWN BY
1	ORIGINAL PRINT	7/18/2022	P. YEUNG
2	UPDATED TOLERANCES	8/9/2022	P. YEUNG

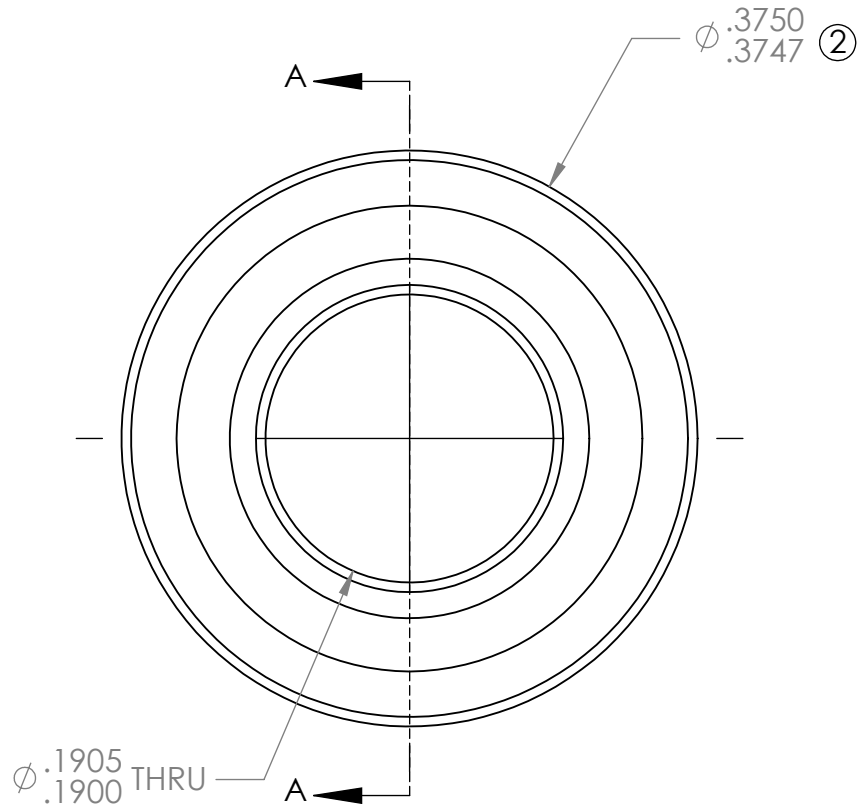
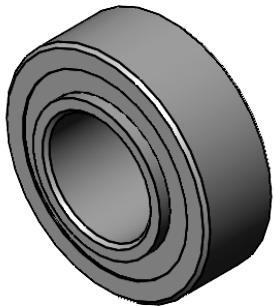

SECTION A-A

*** SEE CAD FOR ADDITIONAL TOOLPATH INFO***



UNLESS OTHERWISE SPECIFIED:		COMMENTS:					
DIMENSIONS ARE IN INCHES		DUAL DIMENSIONS ARE IN MILLIMETERS.					
TOLERANCES: FRACTIONAL $\pm 1/16$ ANGULAR: MACH $\pm 1^\circ$ ANGULAR: BEND $\pm 5^\circ$ ONE PLACE DECIMAL ± 0.1 TWO PLACE DECIMAL ± 0.01 THREE PLACE DECIMAL ± 0.005 FOUR PLACE DECIMAL ± 0.0005		BREAK ALL SHARP EDGES.		TITLE: 188IN ID 375IN OD EXTENDED INNER RACE BALL BEARING			
MATERIAL STEEL		CHECKED	NAME NL	DATE	SIZE	DWG. NO.	REV
FINISH		ENG APPR.		8/9/22	A	am-3681	2
DO NOT SCALE DRAWING		MFG APPR.			SCALE: 8:1		SHEET 1 OF 1
		Q.A.					